

Radiation Safety System (RSS) Backbones: Design, Engineering, Fabrication, and Installation¹

J. E. Wilmarth, J. C. Sturrock, F. R. Gallegos

*Los Alamos Neutron Scattering Center, LANSCE
Division, Los Alamos National Laboratory, Los
Alamos, NM 87545 USA*

Abstract: The Radiation Safety System (RSS) backbones are part of an electrical/electronic/mechanical system ensuring safe access and exclusion of personnel to areas at the Los Alamos Neutron Science Center (LANSCE) accelerator. The RSS backbones control the safety-fusible beam plugs which terminate transmission of accelerated ion beams in response to predefined conditions. Any beam or access fault of the backbone inputs will cause insertion of the beam plugs in the low-energy beam transport. The backbones serve the function of tying the beam plugs to the access control systems, beam spill monitoring systems and current-level limiting systems. In some ways the backbones may be thought of as a spinal column with beam plugs at the head and nerve centers along the spinal column. The two linac backbone segments and the experimental area segments form a continuous cable plant over 3500 feet from the beam plugs to the tip on the longest tail. The backbones were installed in compliance with current safety standards, such as installation of the two segments in separate conduits or tray. Monitoring for ground-faults and input wiring verification was an added enhancement to the system. The system has the capability to be tested remotely.

OVERALL SYSTEM DESCRIPTION

The Radiation Safety System (RSS) backbones are part of an electrical/electronic/mechanical system insuring the safe access and exclusion of personnel to the Los Alamos Neutron Scattering Center (LANSCE) Accelerator and the accelerator's numerous experimental areas (1,2).

The backbone system of cabling and control nodes consists of two heads (dual beam plugs), two backbones (redundant, identical cable runs), four major nerve clusters (node box input points), three tails (three major experimental areas' backbone segments), with

¹ Work performed under the auspices of the U. S. Department of Energy.

a nerve cluster at the tip of each tail (the node box input point) forming a skeletal network of over 3500 feet from the head to the tip of the longest tail. (See Figure 1.)

The two beam plugs (the two heads) are located at the beam entry point into the 201 MHz rf accelerating tanks downstream of the three-energy-transport beam lines. The linac backbone segments are connected to the two RSS safety beam-plugs, 01BL02 and 01BL03 (3). Beam plug 01BL02 is connected to linac "A" backbone segment. Beam plug 01BL03 is connected to the linac "B" backbone segment. The two backbone segments and beam plugs are identical but are physically separated. The beam plugs are held out of the beam by signals from backbone segments when selectable conditions are satisfied.

Several safety design features were included in the system. These are methods for maintaining configuration control of the dual safety beam-plugs, (use of armored cable, redundancy of circuits, physical separation and sensing of faults) and are described in the following paper.

There are two methods, mechanical and electrical, for inhibiting the withdrawal of the RSS beam plugs, when configuration of the facility is to be maintained in an operating mode with no beam delivery beyond the low-energy-beam-transport areas. The plug mechanism has a metal plate that can be installed and held in place by a padlock. This inhibit requires a beam tunnel entry and is generally used for prolonged periods of time. The second method of inhibiting withdrawal is by a push-button switch at the junction boxes at the upstream end of the backbone. These switches and associated junction boxes have padlock attachments that allow the installation of the padlocks outside the beam tunnel. These are generally used for short periods when control of the safety beam plugs is needed. Configuration control is an important consideration in the design of the system.

The color "school bus yellow" was selected for all RSS backbone junction boxes and cable so that they could be easily distinguished. The cable used for the primary backbone is armored one-pair, shielded, #16 AWG with unique color codes for the four different runs of cable comprising the linear accelerator (linac) segment. (See Figure 2.)

The tails or experimental area segments are armored one-pair, shielded, #16 AWG cable. The three experimental area segments all use the same type cable and are called "Line D (LD)" backbone, "Line X (LX)" backbone, and "Line A (LA)" backbone. These cables connect the node junction boxes together with special termination of the armored jacket (yellow), which is similar to .75"-diameter oil-tight flexible conduit. The insulation of the one-pair within the armored jacket runs inside a 44" wire-way, from the armor cable termination to the junction box terminals, where connection is made at the junction box back-plate input terminals.

Physical separation of the linac segment of the armored-cable runs is accomplished by using the three vertically stacked horizontal cable trays that run the length of the accelerator-equipment building. The accelerator equipment building is a continuous structure over 2500 feet long. The cable runs were separated into three trays. The "A" backbone (hot) was installed in the top tray. The "B" backbone (hot) was installed in the middle tray, and the "A" and "B" returns were installed in the bottom tray. The physical separation of the cable in the three trays was to prevent any common mode damage to the cable on the long horizontal runs.

The input cabling to the backbone node boxes is constantly verified by a "sense" circuit board, designed locally. Each input is monitored for shorts and ground faults. If a fault is detected, it is displayed locally and remotely from each node box of the system.

The linac-backbone segments and experimental-area segments are powered by a plus/minus, 24 V power supply attached in the node boxes at the end of the linac and the experimental areas. The voltage is fed over the cable running toward the front of the

accelerator. Dual isolated power supplies allow ground-fault detection to be used over the entire backbone cable segments (Figure 2).

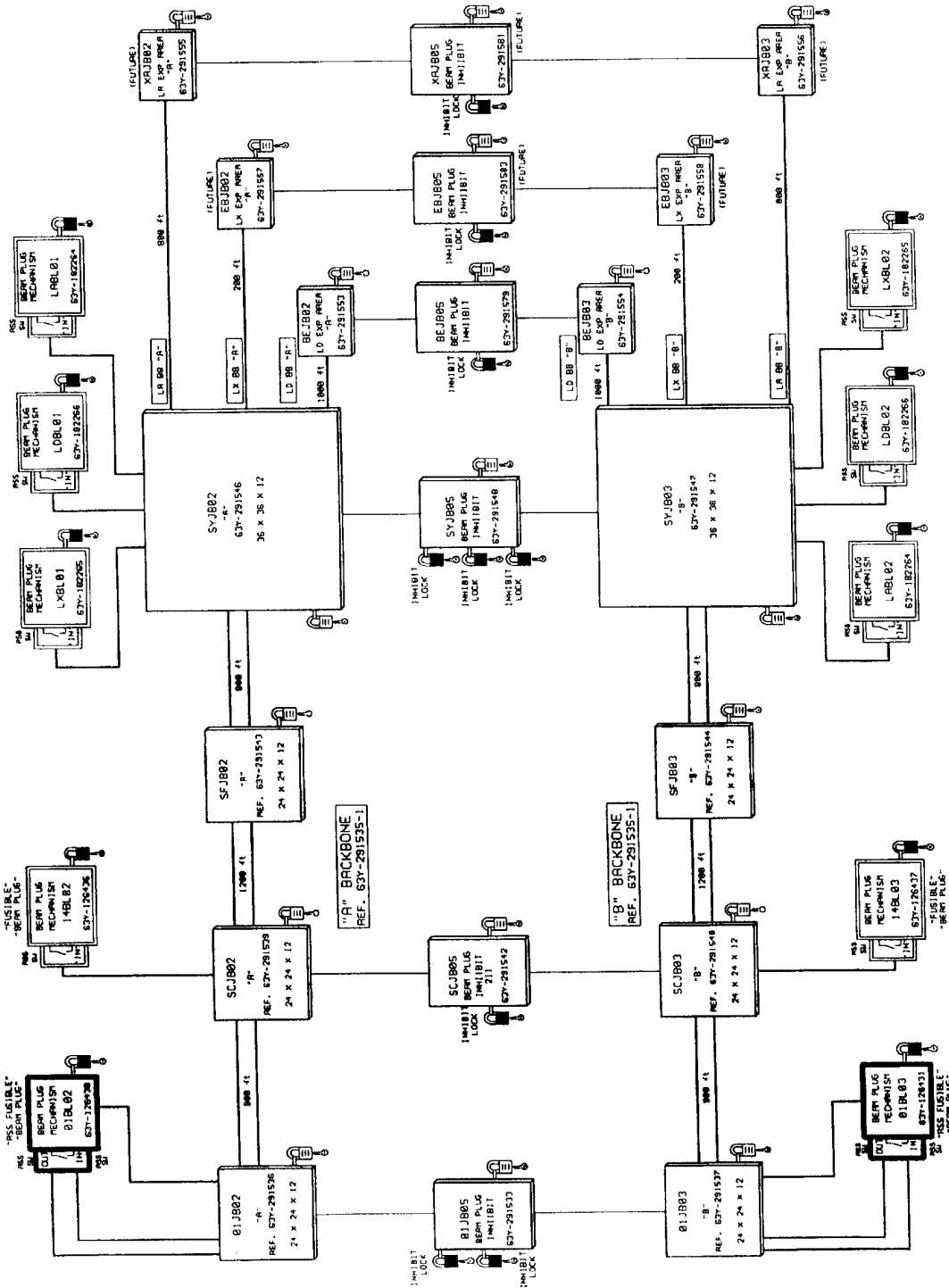

FIGURE 1. Overall RSS block diagram.

System Junction Box Description

Ease of maintenance, separation of components, and configuration control issues were considered in the system layout within the node junction boxes. LEDs are used to convey information through a window in the box lid, thus permitting information as needed without compromising access to components.

The interior of the box has a swing-out bent panel with a window and power supply mounting hardware. The side of the enclosure has openings for mounting two surge-protected outlets outside the enclosure. The node boxes are two basic sizes. The smaller version is 24 inches by 24 inches by 12 inches deep and the larger is 36" × 36" × 12". All boxes are Hoffman-Enclosure-Concept style, specially ordered with a window in the hinged lid of the box. The smaller version is used where space may be a limiting factor and few inputs are required. The window on the lid is for information display that is developed within the node. Decals are fabricated and applied to the inside of the windows to provide appropriate display information. The larger enclosure is used where space is not a limiting factor and as many as 12 inputs can be accommodated. The bottom plates of both boxes are used for the RSS wiring and RSS component-mounting surface. The boxes have a Hoffman-keyed lock in the upper latch to secure the lid of the enclosure. The keys are issued to maintenance personnel. The swing-out panel is secured by an RSS padlock, which is issued and controlled by the RSS Engineer.

The wiring located on the bottom plate is physically isolated from the rest of the junction box by the swing-out plate. The swing-out plate contains power supplies and their associated sense- and ground-fault-detection printed wiring boards (PWB). The power supply PWB boards are for distribution of voltages and detection of ground faults. There is direct wiring of the relay outputs on the bottom plate to the display PWBs located on the inside of the window found in the box lid. (See Figure 3.)

The bottom plate is the mounting panel for the quad-sense-evaluation PWBs which are wired between the terminal strip input and the coil of the relay associated with that particular input. There are four circuits contained on each PWB. There is a single output contact from each board, wired in series with the other sense PWBs, if installed, that is the sum signal, used to trip the fault relay and set the corresponding fault indication. The operation of the quad-sense PWB requires each input to the backbone to have a 160-ohm, .25 W carbon-film resistor installed at the end of cabling, preferably on the switch contacts of the input device. The output of the quad-sense circuit must be loaded with a resistance or coil of a relay to operate the sense circuit. (See Figure 4.)

The display of information at each junction box or node location is accomplished by a universal-display printed circuit board attached to the rear of the junction box window with cabling run to one pole of each backbone relay. A decal with the information for a particular box is installed between the window and the printed-circuit board with small, clear openings for the display LEDs.

The concept boxes were ordered from Hoffman Enclosures with several special features. The door of the enclosure also serves as the window for information display. The swing-out panel is used for the mounting of components and provides a barrier to access of the bottom plate. The bottom plates were standard, with the hardware mounting done after delivery. All incoming cable to the boxes is protected by wire-way, conduit, or tray until it is terminated inside the enclosure. The layered concept of the boxes allowed the fabrication of bottom plate wiring and component mounting in parallel with the swing-out plate by outside fabrication vendors. The mounting of boxes, connecting of the wire-way, conduit and tray, and installation of 110VAC power was completed simultaneously by electrician crews. The armored cable installation was

accomplished before the mounting of boxes due to the long lead-time of fabrication by the Hoffman Enclosures and the early ordering and timely arrival of the cable.

The wiring from the terminal strips to the relay sockets is the least modular feature of the backbone enclosures. The wire is terminated in wiring ferrules at the terminal strips and relay sockets. The appropriate-sized ferrule is crimped on the wire to match the gauge. The ferrules provide the best mechanical attachment for electrical connections, prevent strands from fraying, and secure the capture of exposed wire in terminal wells and under screw clamps.

The physical-separation design criteria was used on the component layout throughout the junction boxes. Terminals are snap-on style with three colors (blue, orange, grey), used with mounting rails specified by European standards (DIN-EN 50 022) separated by barriers and nomenclature plugs for each input or output set (DIN-rail).

A single Allen-Bradley programmable controller (PLC) is installed at each node-box location to allow remote read-out of the status of both backbones at that location. The Allen-Bradley PLCs are connected together by a local area network exclusive to the RSS backbones.

System Installation

The accelerator facility's cable plant location allowed for the installation of cable and boxes during operating cycles of the accelerator. The linac equipment-aisle is a single, continuous building, 2500 feet in length and 10 feet wide at the narrowest doorway. The pulling of cable was accomplished by the use of a radio-controlled 4-wheel-drive, battery-powered vehicle that traveled in the twelve-inch-wide cable tray. This vehicle pulled a string, which was used to attach a pull-rope. The pull-rope was pulled by a battery-powered golf cart which is small enough to travel the hallway yet strong enough to pull bundles of cable from spools over the 2500-foot installation. The use of these vehicles allowed for safe and efficient cable installation. The vehicle remote-control capabilities reduced the need for climbing with ladders to access the cable-tray system (located in the ceiling area of the equipment building) to a minimum.

The current cable plant was installed in 1997/1998. There were several earlier prototype installations that were partially reused in the final version. Single, armored-cable runs with one cable for "A" and one cable for "B" were installed in 1995. They connect the experimental area "LD" to the switchyard (SY) equipment aisle node boxes. Two other experimental areas have temporary cables installed, awaiting expansion of the experiments in those areas for the node boxes and armored cable.

The design philosophy for the linac backbone was based on the backbone installation of 1995. The linac backbones were to be as physically separated as the facility and existing equipment would allow. The design criteria for simple, rugged, and expandable installations were used where possible. Relay logic was selected for ruggedness. The design of the safety-beam-plug control elements was incorporated into the linac Backbone concept. The 1995 backbone voltage was fed from the junction boxes that controlled the beam plugs.

The backbone components were selected or designed so that they are easily removable and replaceable. The relays are plug-in style with DIN-rail mountable sockets. The PWB's are tray-contained for DIN-rail mounting and have connectors for all input/output wiring to allow quick disconnection and replacement. The power supplies are screw-mounted to the swing-out plate by use of a mounting frame. Connectors are installed on the end of the cabling from the power supply to sense and distribution PWBs.

The wiring of the backbone circuit within each junction box is a larger AWG wire size and is color coded to match the color code of the armored-cable landing on the terminals from outside the box.

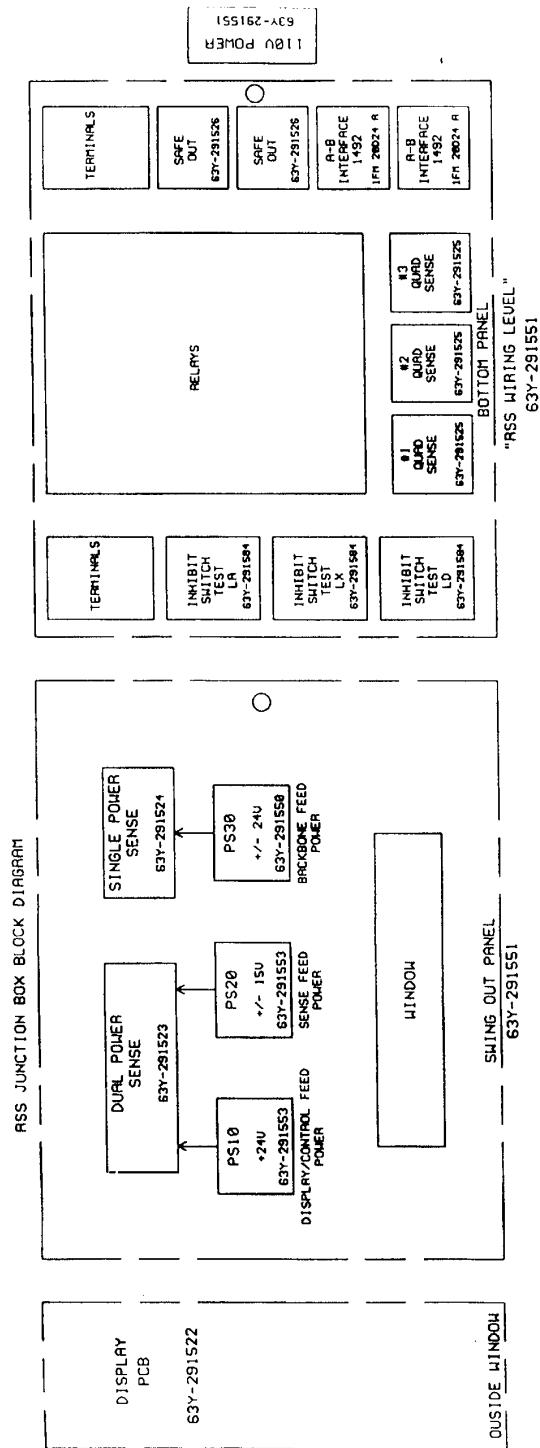

FIGURE 3. Typical junction box block diagram.

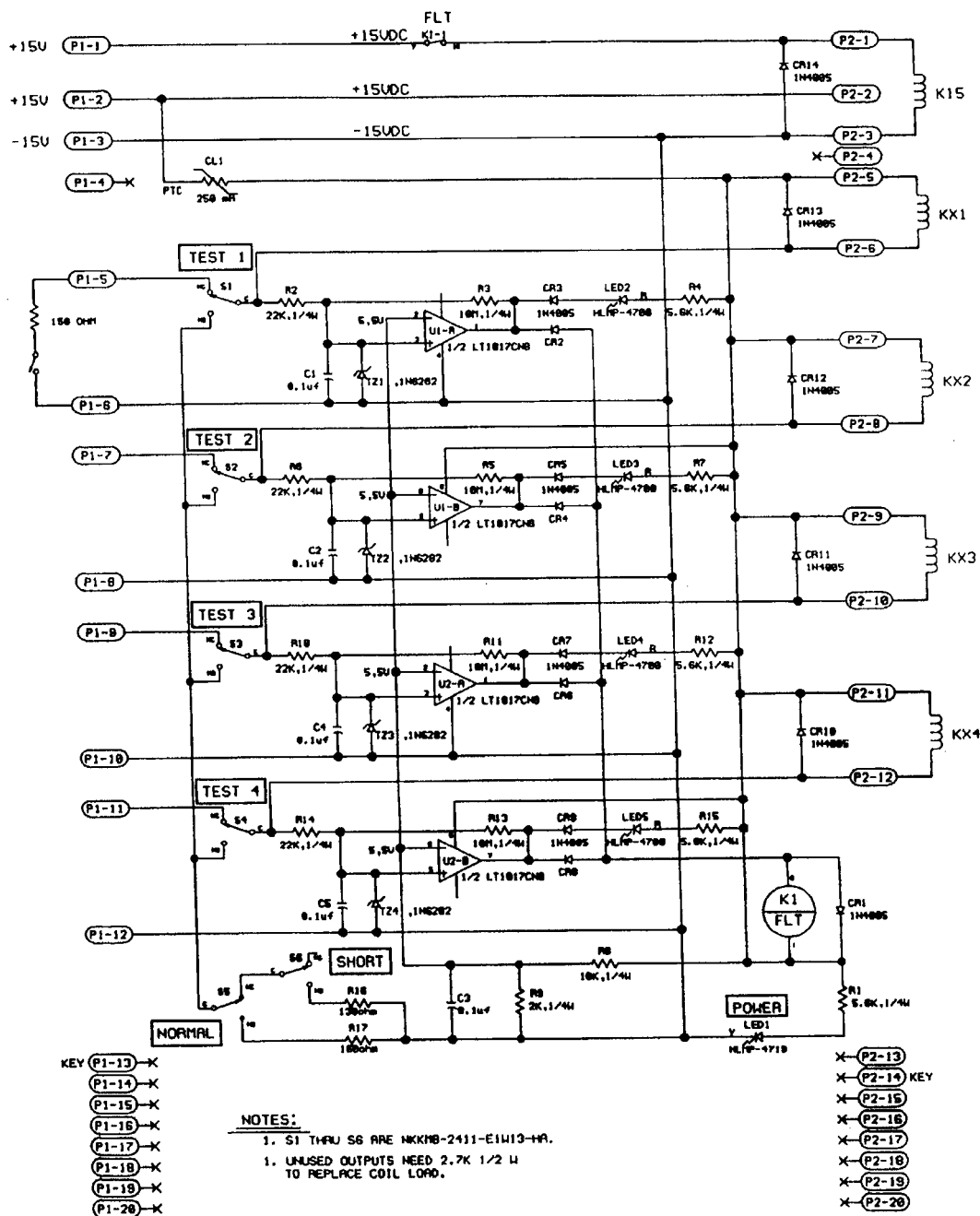

FIGURE 4. Quad sense PNB schematic.

Summary of Design Features

1. Redundant. Two separate cable plants with two separately controlled safety devices, i.e., RSS-rated beam plugs in the low-energy-transport section of the accelerator.

2. Robust and strong. Junction boxes, armored cable, large AWG cable, tray and wire way.
3. Expandable. The capability to add future backbones to the existing system. The capability to add inputs to existing node junction boxes.
4. Simple. The backbones consist of wire and relay contacts.
5. Easily identified components. The color "school-house yellow" is used for all cabling and junction boxes. All internal wiring is color coded and documented.
6. Physically separated. The separation of cabling in tray and wire way. The separation of terminations and components within junction boxes.
7. Testable. Accelerator operational testing and verification ability. Input-by-input or component-by-component.
8. Capable of remote configuration. The ability to select different operational modes from the Central Control Room by operators, i.e. computer control of equipment affecting operational modes.
9. Interruptible. Operations has the ability to interrupt the backbones with a single crash button. The automatic insertion of beam plugs with loss of any input to the backbone.
10. Verifiable backbone wiring. Ground fault indication at both local/CCR locations.
11. Verifiable input wiring. Testing available for short, open, and ground fault with indication at both local/CCR locations.
12. Displayable logic. The remote display of information about the backbones is accomplished with Allen-Bradley PLCs to VME via local area networking.
13. Access controllable. All junction boxes have a padlockable RSS wiring level. Access granted by RSS Engineer and documented controlled key.
14. Visually accessible. The design of windows in the door and on the swing out panel allows visual inspections of the quad sense boards LED's for problem identification. Logical display and information is on the outside window.
15. Modular. Design consideration for all components was plug-in replaceable. PWB's are in trays that are DIN-rail mountable. Relays are mounted in sockets. Terminals are DIN-rail mountable with screw connections. DIN-rail-mountable identification plugs and test equipment.
16. Label. Everything is labeled. Cables, PWB/ trays, terminals, power supplies, relays, connectors, junction boxes, switches, areas, and nodes.
17. Relay pole assignments. All relays used in the backbones have the same assignments. Pole 1, BB logic wiring. Pole 2, Allen-Bradley wiring. Pole 3, safe-out wiring. Pole 4, local display wiring.
18. Event counting. With the Allen-Bradley PLC it is possible to count the times that beam plugs are inserted. To measure the time between the two safety plugs reaching their in or out limits. The timing of any operational parameter associated with the backbones. The Allen-Bradley PLC's are read only, this means the PLC could be removed from the systems with no loss of the backbones operation other than remote display.
19. Organized documentation. The schematics for the junction box point-to-point wiring and the decal for the door window are under one drawing number. The number is displayed on the window decal. There is a different drawing number assigned for each junction box.
20. Dual outputs. Each system feeding inputs to the backbones requires dual outputs. A outputs are fed to the A backbone. B outputs are fed to the B backbone. PACS systems have redundant individual testable outputs.

21. Ferrule terminated wiring. All backbone wiring is terminated with ferrules which require a crimping tool and ferrules for different size wire. The ferrules offer a more solid contact with screw terminals. Stranded-wire fraying and loose ends are eliminated.
22. Protected 110VAC. The use of surge-protected receptacles with individually assigned and padlock-compatible circuit breakers for each node box.
23. Regulatory Guidance. DOE Order 5480.25, Safety of Accelerator Facilities. LANL Laboratory Standard LS107-01, Accelerator Access-Control Systems. LANSCE 6 AOT-6-95-QA-4, Radiation Security System Quality Assurance Management Plan.

Summary of Fabrication and Installation Features

1. Johnson Controls Northern New Mexico (JCNNM) electrician teams were specially trained in the requirements of backbone installation with the development of armored cable termination. JCNNM and Los Alamos Neutron Science Center (LANSCE) Protective System Team members developed cable pulling techniques that allowed for faster and safer cable installations over lengths of 2500 feet.
2. Dawn Electronics, vendor for fabrication of backbone RSS level wiring bottom plates, was instructed in specialized wiring requirements. The construction of the components was accomplished off-site.
3. Northern Design, vendor for fabrication of backbone printed circuit assemblies with DIN rail-mounting of tray components with assembled printed circuit boards.
4. Protective Systems Team, LANSCE-6, contributed with fabrication, installation, oversight and the specialized fabrication of Central Control Room display equipment. The installation of the Allen-Bradley equipment, with development of the logic and interfacing to VME equipment, was accomplished by team members.
5. Fabrication, installation, training and checkout was a three-year project. Associated with the installation of the RSS backbones were seven personnel access control systems (PACS) area installations which were connected to the linac backbones.

REFERENCES

- [1] Gallegos, F. R., "LANSCE Radiation Security System (RSS)," presented at the Conference on Health Physics of Radiation Generating Machines—30th Midyear Topical Meeting San Jose, CA, January 5–8, 1997.
- [2] Sturrock, J. C., F. R. Gallegos, M. J. Hall, "LANSCE Personnel Access Control System (PACS)," presented at the Conference on Health Physics of Radiation Generating Machines—30th Midyear Topical Meeting San Jose, CA, January 5–8, 1997.
- [3] Jones, K. W., W. Boedeker, A. Browman. "Use of Fusible Beam Plugs for Accident Mitigation at the LANSCE Complex," presented at the Conference on Health Physics of Radiation Generating Machines—30th Midyear Topical Meeting San Jose, CA, January 5–8, 1997.