

Beam Position Monitor System of DAΦNE

A. Stella, A. Drago, A. Ghigo, F. Marcellini, C. Milardi,
F. Sannibale, M. Serio, C. Vaccarezza

*INFN Laboratori Nazionali di Frascati
00044 Frascati (Roma), Italy*

Abstract. The DAΦNE beam position monitor (BPM) system consists of 150 monitors installed all along the machine. Design issues, calibration procedures, experimental results and performance of the system are described. The closed orbit in the main rings is extracted from the BPM signals through narrowband receivers (realized by Bergoz Precision Beam Instrumentation for DAΦNE), then acquired and processed by a real-time task based on four independent processors dealing with different machine areas. The data acquisition system is integrated in the DAΦNE control system and measures five complete orbits in a second. Implementation criteria, measurements and results are reported.

OVERVIEW OF THE BPM SYSTEM

The Φ-Factory, DAΦNE, is a high-current multibunch e^+e^- double-ring collider, presently being commissioned at INFN-LNF. Electron and positron beams are generated and accelerated along a linac up to the nominal energy of 510 MeV, stored and phase-space damped in the accumulator ring before injection into the main rings through a ~ 100 m transfer line.

Table 1 summarizes some of the DAΦNE operating parameters relevant to the diagnostic system:

TABLE 1. DAΦNE Parameters

	Accumulator	Main Rings
Energy	510MeV	510MeV
rf frequency	73.65 MHz	368.25 MHz
Number of bunches	1	120
Single bunch current	150 mA	40 mA
Bunch length	100 ps	100 ps
Revolution frequency	9.2 MHz	3.06 MHz

Because of the various requirements of each part of DAΦNE resulting from the different beam characteristics and the vacuum chamber geometry, several different pickup devices and monitor configurations have been designed and installed in the transfer-lines, accumulator and main rings. These include short-circuited strip-lines, matched striplines, button electrodes, and special monitors for use in the interaction regions.

The low intensity of the beam in the transfer lines (TL) and the accumulator requires a high-sensitivity BPM. For this reason, mainly stripline monitors are used. The four electrodes are $50\ \Omega$, stainless-steel strips, short-circuited at the downstream end. This is mechanically convenient and has no relevant effect on the upstream signal. Single strips in the same monitor are matched within $0.05\ \Omega$ to each other.

The acquisition system in the accumulator and transfer lines is simpler than the main rings' system. BPM signals are multiplexed and acquired using an oscilloscope remotely controlled through GPIB and a LabView application, which also provides a versatile user interface.

TABLE 2. DAΦNE Beam Position Monitors Summary Table

	BPM	Total BPM
Damping Ring	short circuited strip line	4
	button electrodes	8
Transfer Lines	short circuited strip line	23
Main Ring e ⁻	button electrodes	35
Main Ring e ⁺	button electrodes	35
Interaction Region	button electrodes	9+9
	matched strip line	4+4

In order to correct the closed-orbit distortion and optimize the operation of the main rings, 35 BPMs have been installed all along each ring and a further 13 BPMs are situated in each interaction region. The beam position monitors of the main rings are detected and processed by a dedicated acquisition system, described in the next sections, which provides the closed orbit for both the positron and electron rings at a fast rate.

Matched stripline monitors and electrostatic monitors with six-button electrodes have been developed for interaction regions to allow simultaneous measurements of the transverse position of positron and electron beams (1). The stripline monitors are $50\ \Omega$ strips, matched at both ends and with a directivity of $\sim 25\text{dB}$.

MAIN RINGS SYSTEM

Pickup Characteristics and Calibration Procedures

The button electrodes, manufactured by Metaceram (FR), are 10 mm in diameter, have a matched impedance of $50\ \Omega$ and a typical capacitance of 4.2 pF. They were

designed to produce acceptable signals and to keep the vacuum chamber impedance as low as possible. The capacitance of each electrode was measured before mounting. An example of reflected waveform from a capacitance measurement based on the TDR method (2) is shown in Figure 1.

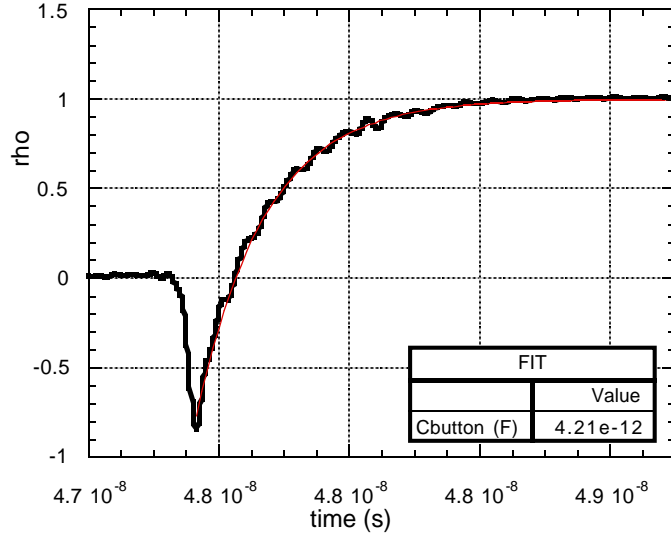

FIGURE 1. TDR measurements of the button pickup electrode.

Buttons with similar capacitance have been grouped together in each monitor in order to minimize the electric offset error. This error can be estimated deducing $\Delta V_b / \Delta C_b$ from the equation that represents, in the frequency domain, the voltage V_b induced by the beam at the external termination as the product of the transfer impedance Z_b times the beam current spectrum I :

$$V_b(\omega) = Z_b(\omega) \cdot I(\omega) = F\phi R_0 \left(\frac{\omega_1}{\omega_2} \right) \frac{j\omega / \omega_1}{1 + j\omega / \omega_1} \cdot I(\omega) \quad (1)$$

where $\omega_1 = 1/R_0 C_b$ and $\omega_2 = c/2r$ with C_b the button capacitance to ground, r the button radius, c the speed of light, $\phi = r/4b$ the coverage factor, b the half height of the vacuum chamber and F a form factor which depends on the vacuum chamber geometry (3). In our monitors, the value of F ranges from ~ 0.6 in the rectangular types to 1 in the round ones.

The capacity values C_b in each monitor are matched within 0.01 pF, resulting in an electrical offset error for the BPM installed in the main rings within 50 μm , in the worst case.

Since the vacuum chamber cross section is variable along the ring circumference, several different configurations of BPM have been developed (Figure 2).

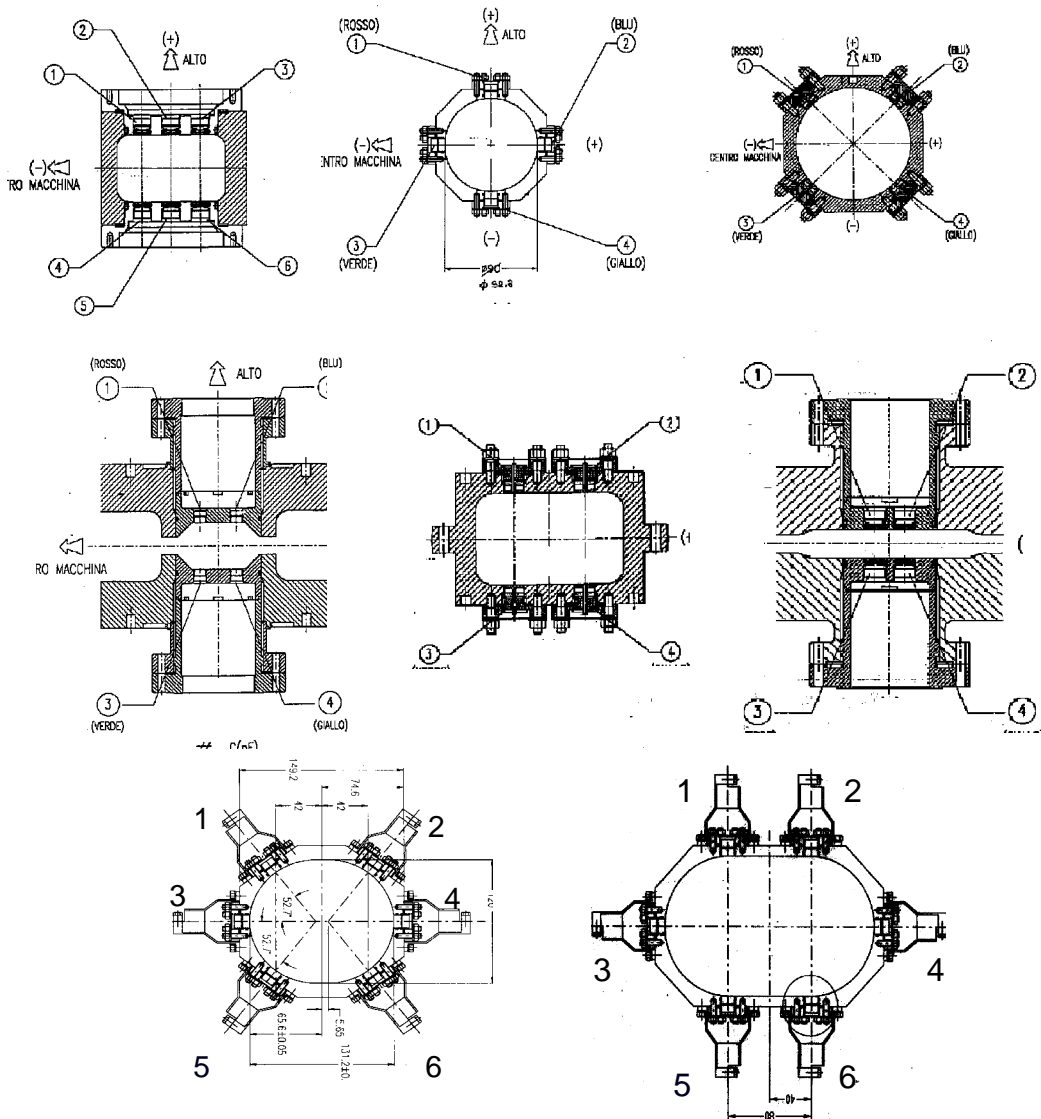

FIGURE 2. Schematic layout of the BPM installed in the DAΦNE Main Rings.

An accurate calibration of each type of BPM installed has been performed, with both numerical simulations and bench measurements (4), to recover the non-linearity of the transfer function. Starting from calibration data, a non-linear fit of two dimensionless quantities, derived from the signal induced on the electrodes, is used to reconstruct accurately the beam transverse position.

Table 3 summarizes, for various BPM configurations, the beam position reconstruction error (rms) applying a fourth-order polynomial fit in a 20 mm ~ 20 mm zone around the center of the monitor.

TABLE 3. Reconstructed Beam Position Error

BPM type	ΔX_{rms} fit error	ΔY_{rms} fit error
Round diagonal	21 μm	21 μm
Dipole	22 μm	39 μm
Wiggler	33 μm	93 μm
Rectangular	26 μm	29 μm
Round orthogonal	14 μm	14 μm

Detection and Data Acquisition

The beam signals from the pickup electrodes of each BPM are transmitted through independent good quality coaxial cable having an average length of 25 m up to the detection electronics.

The signal detection circuit has been developed by Bergoz Precision Beam Instrumentation with particular specifications for DAΦNE (Table 4).

TABLE 4. BPM Detection Electronics Parameters

rf detection frequency	736.515 MHz
if processing frequency	21.4 MHz
Minimum input signal detected	-73 dBm
Dynamic range	80 dB
Button sampling frequency	2.5 KHz

In order to measure beam position with any multibunch configuration (up to 120), the pickup frequency of 736.5 MHz has been chosen. It corresponds to twice the accelerating rf frequency and to a typical button transfer impedance of $\sim 0.2 \Omega$.

The signal from the BPM electrodes are time-multiplexed into a superheterodyne receiver, which converts the beam-spectrum-selected harmonic to an intermediate frequency, $if = 21.4 \text{ MHz}$, before amplitude detection.

The demodulated signal is demultiplexed into four values that are stored in analog memories. The four signals are summed and the sum is maintained constant by an automatic gain control, which makes it possible to obtain the pseudo-beam positions by simple sums and subtractions between the demodulated voltages (5, 6).

The Bergoz detectors and all of the hardware for the acquisition are distributed in four racks located in different areas of the Main Ring Hall. Each BPM board provides two analog voltages, in the range $[-10 \text{ V}, 10 \text{ V}]$, which represent the linear combination of the button signals used to deduce the transverse beam position (x, y) with the fitting algorithm described above.

The signals coming from the detection electronic boards are grouped in one of the four independent racks, then multiplexed and acquired (Figure 3).

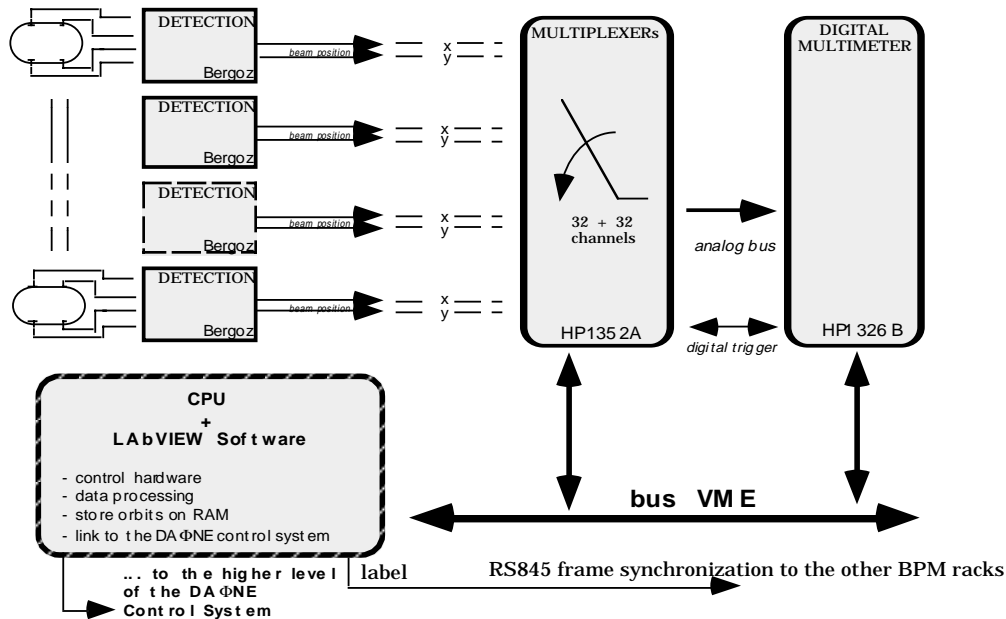

FIGURE 3. Schematic of the Main Rings BPM acquisition system.

The acquisition system which reads and processes the two analog outputs from each monitor has been developed following the VME standard, using mainly commercial hardware.

An independent processor, based on a Motorola 68000 CPU, running a purpose-built LabView application, controls two HP1352A FET Multiplexers and a HP1326B Digital Multimeter.

The two FET multiplexer modules provide high-speed switching up to 64 channels, and are directly connected to the digital multimeter. A scanning list of channels is downloaded into a RAM on the multiplexer modules at the startup and scrolled automatically during the acquisition (7).

The scanning operation does not require any intervention from the central CPU until the end of the whole acquisition of all the BPMs in the scan list. The trigger for channel advance comes from two handshake lines that directly link the HP modules, while an analog bus connector provides the link to the voltmeter for the signals to be measured.

This working mode allows a fast acquisition of the closed orbit since, during the measurements, each CPU is free to process the previously measured data in order to apply the linearization fit and to store the beam positions in a circular buffer memory. The acquisition rate is ~ 5 orbits/sec. Each processor deals with one quadrant of the closed orbit, both for the electron and positron rings. One of the four processors (the master) sends a “start” command along with the “actual time” information on an RS485 line to the other three processors (the slaves).

The four processors are fully integrated in the DAΦNE control system, both from the hardware and the software point of view. The orbit data are directly accessible from the control system user interface, which provides many tools to display the closed orbit throughout the whole machine, as well as in the interaction regions, where a local orbit analysis and correction is necessary in order to control the interaction point and then the luminosity.

Data from the BPM system are also accessed from automatic tasks recording the beam response to different localized kicks by the corrector magnets, the so-called response matrix, used for machine modeling.

System Performance

The response of the whole BPM system has been analyzed as a function of the stored beam current. In this way, all the different device parts—pickup, cable, detection and acquisition equipment—have been checked. Moreover the error affecting the position measurements at low current has been determined.

One set of measurements of one hundred consecutive orbits each, at several beam current values, has been recorded. The difference between each averaged orbit and the reference orbit, measured at ~ 18 mA, is reported for different BPMs located along the positron ring (Figures 4–5).

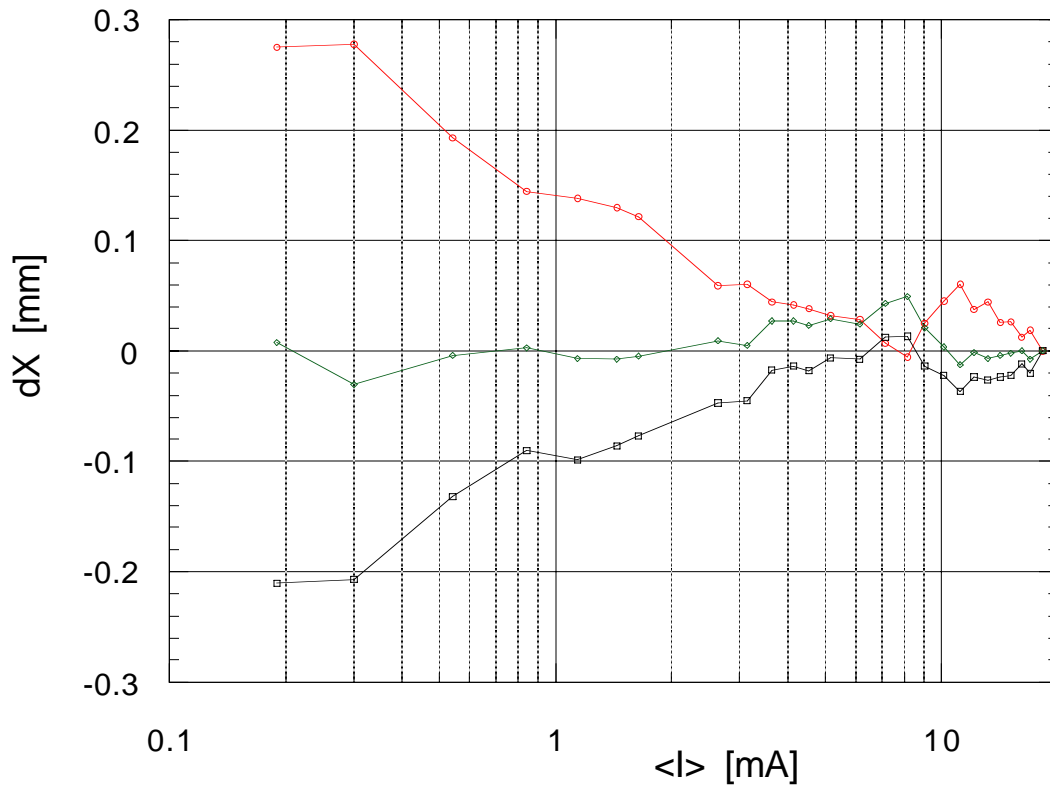

FIGURE 4. X mean position vs. beam current for different monitors.

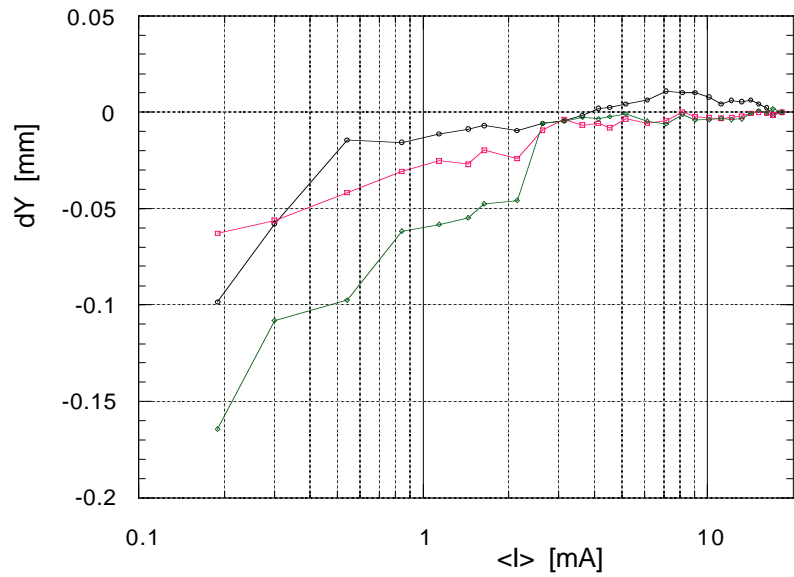

FIGURE 5. Y mean position vs. beam current for different monitors.

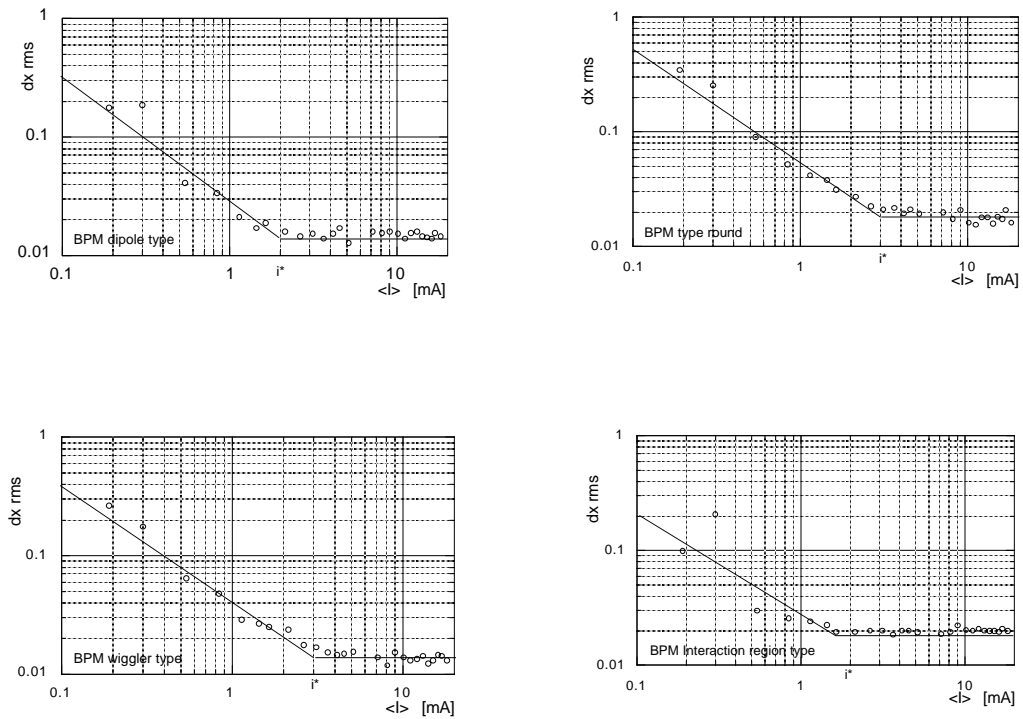

FIGURE 6. Error position rms vs. beam current for different monitors.

The rms beam position error δx (Figure 6) is initially inversely proportional to the beam current $\langle I \rangle$, and asymptotically approaches about 0.02 mm for currents above the threshold I^*

$$\delta x \langle I \rangle = k \text{ for } \langle I \rangle < I^* \quad (2)$$

The k and I^* values for different type of monitors are reported in Table 5.

TABLE 5. k and I^* Values for Different Types of Monitors

Type	k [mm mA]	I^* [mA]	δx_{rms} [mm]
Round diagonal	0.05	3.1	0.02
Rect	0.04	3.1	0.018
Dipole	0.03	2.1	0.017
Wiggler	0.04	3.1	0.018
Interaction region	0.02	2.1	0.02

A stable measurement at a current value as low as 0.19 mA is the lowest limit of our analysis so far.

ACKNOWLEDGMENTS

The BPM system is the most extensive of all the DAΦNE diagnostics, numerous people cooperated in the various facets of the project.

The authors wish to thank Oscar Coiro, Donato Pellegrini, Olimpio Giacinti, whose support during commissioning has been of great importance in the system realization. The help of Carlo Marchetti for all the bench measurements is gratefully acknowledged.

We are grateful to Julien Bergoz and Klaus Unser for helpful collaboration.

REFERENCES

- [1] Serio, M., A. Stella, C. Vaccarezza, "Beam Position Monitor for the DAΦNE Interaction Regions," Presented at the Diagnostic Particle Accelerator Workshop 1997, Frascati, Italy.
- [2] Hewlett-Packard, "TDR fundamentals," App. note 62.
- [3] Marcellini, F., M. Serio, A. Stella, M. Zobov "DAΦNE Broad Band Button Electrodes," *Nuclear Instr. Meth. in Phys. Res. A* **402**, pp. 27–35 (1998).
- [4] Ghigo, A., F. Sannibale, M. Serio, C. Vaccarezza, "DAΦNE Beam Position Monitors," Presented at the Beam Instr. Workshop, Argonne, 1996.
- [5] Unser, K. B., "New Generation Electronics Applied to Beam Position Monitors," Presented at the Beam Instr. Workshop, Argonne, 1996.
- [6] Bergoz Precision Beam Instrumentation, "BPM Board User's Manual."
- [7] Hewlett-Packard Company, HP E1326B and HP1352A Digital Multimeter and FET Multiplexer User Manuals.