

# Beam Current Monitors at the UNILAC

N. Schneider

*Gesellschaft für Schwerionenforschung mbH  
(GSI), D-64291 Darmstadt*

**Abstract.** One of the most basic linac operation tools is a beam current transformer. Using outstanding materials, the latest low-noise amplifiers, and some good ideas, a universal current monitoring system has been developed and installed at the UNILAC at GSI. With a dynamic range of 112 dB, covering the low-current range down to 100 nA peak to peak at  $S/N=1$ , as well as 25 mA pulses, provided for high-current injection to the SIS synchrotron, a well-accepted diagnostic instrument could be placed at the disposal of the operators.

## INTRODUCTION

Due to the upgrading of the prestripper section of the UNILAC accelerator at GSI/Darmstadt, it was necessary to improve the performance of the current transformers in the beam lines.

To measure currents with good sensitivity ( $S/N \gg 1$ ), it is mandatory to have a high current transfer ratio, i.e. a low number of secondary windings, while for low droop it is necessary to have high inductance, i.e. a high number of secondary windings.

This problem has been solved by using ultra-low-noise amplifiers, high-permeability cores with low magnetostriction, signal clamping and the application of a low-frequency feedback (see Fig. 2), which corrects the first 8ms of the signal to less than 0.5% droop.

## HEAD AMPLIFIER

The “heart” of the head amplifier is an operational amplifier of outstanding performance: the input noise is less than that of a  $50\Omega$  resistor and the slew rate is  $15V/\mu s$ . Integrated in the head amplifier are also a clamp and a differential signal driver, as well as the ability to perform range switching.

To accurately determine the mean value of the beam current, an integrating measurement must be performed. The integration time should correspond to the gate pulse duration.

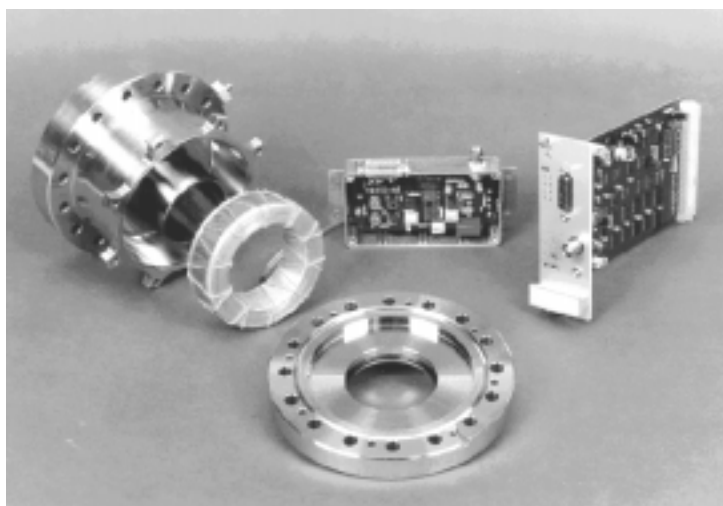

**FIGURE 1.** Picture showing core, housing, and head amplifier and digitizer, connected with a ten-wire twisted-pair cable of a maximum of 300 feet in length.

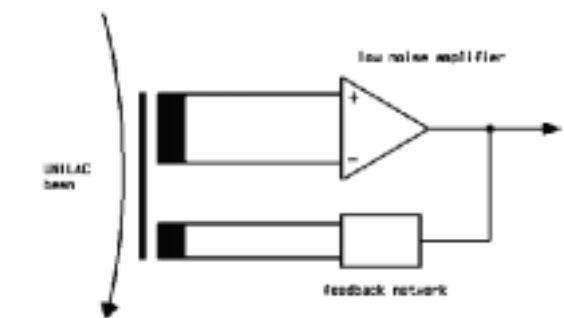

**FIGURE 2.** Schematic of head amplifier.

## INTEGRATING DIGITIZER

A simple method of bringing the integration time into correspondence with the gate pulse duration is integration by quantified charge compensation. The signal to be digitized is integrated by an analog integrator, and compensated by pulses of constant amplitude and duration, but of opposite polarity (see Fig. 3).

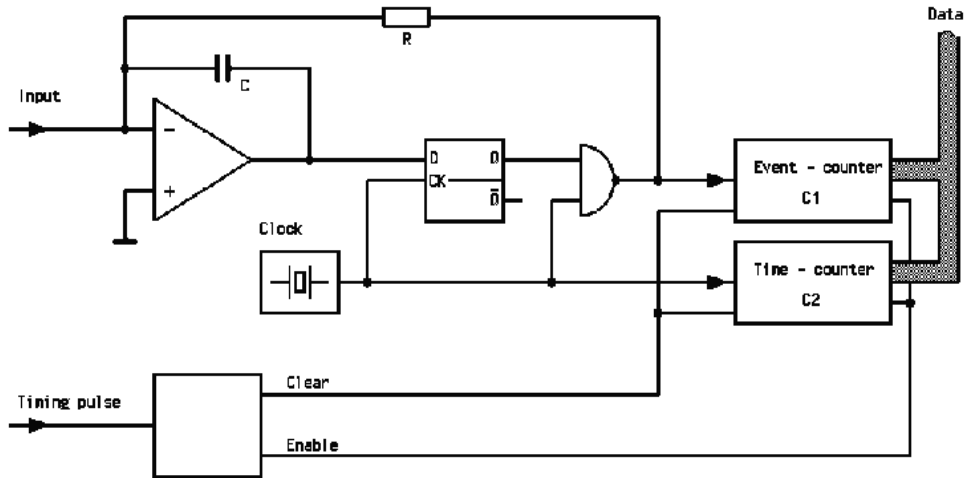

**FIGURE 3.** Schematic of integrating digitizer.

The digitizing sequence is started by a timing pulse, delivered by the UNILAC timing system, which is also used to disable the clamp in the head amplifier.

In the first stage a small capacitor ( $C$ ) of an integrator is charged (see Fig. 3). When the output passes a threshold, a D-flipflop is set. With the following clock pulse, a well-defined charge amount is subtracted from the capacitor through the resistor ( $R$ ) and, at the same time, a counter ( $C1$ ) is incremented. A second counter ( $C2$ ) is increased during the timing pulse by the clock pulses, representing the pulse duration.

The practical setup works with clock frequencies up to 24 MHz. Of utmost importance is a very stable power supply, because its value affects the result most directly.

After one measuring sequence (machine cycle) the two counters contain:

$$C1 = i \times t \times f_c \times C_f \quad (1)$$

$$C2 = t \times f_c \quad (2)$$

where  $i$  = current,  $t$  = pulse width,  $f_c$  = clock frequency and  $C_f$  = constant factor. The quotient  $C1/C2 = i \times C_f$  gives the mean value of the current, independent of the pulse length.

As it is well known that laboratory values are something entirely different than the rough business at the beam line, we found that the noise floor due to (external) hum and microphony was measured to be more than 500 nA peak-to-peak, reducing the dynamic range.

Therefore, it was decided to further shift the range up to 50 mA, giving up the high sensitivity, but keeping the dynamic range. Nevertheless, the installed current monitors are very useful linac equipment and well accepted by the operating crew.

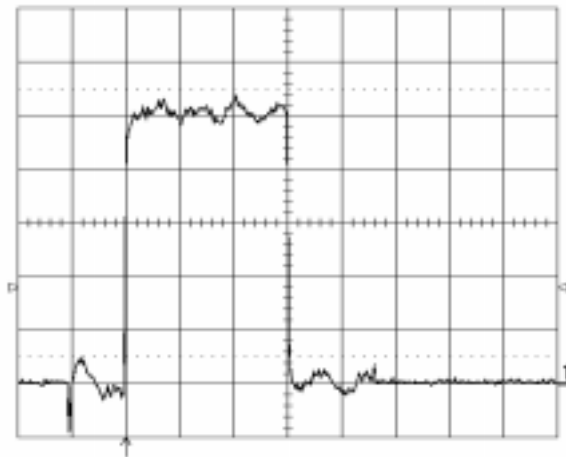

**FIGURE 4.** Scope picture showing a 5  $\mu\text{A}$  pulse of 600  $\mu\text{s}$  duration within the 1 ms clamp pulse, risetime  $< 8 \mu\text{s}$ .

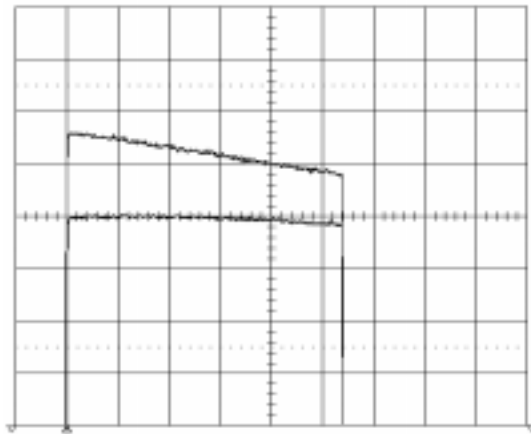

**FIGURE 5.** Scope picture showing a 11 ms pulse with and without using the feedback loop. Vertical scale is 5% of the signal magnitude.

In the future the equipment will be extended. The interlock system of the UNILAC has to be improved due to higher beam intensities. By monitoring the difference between subsequent beam current transformers, any beam losses between them can be detected and an interlock invoked.

## CONCLUSION

It is possible to work near the physical limits of monitoring beam currents if some certain facts are attended to, such as:

- using high permeability cores

- good shielding
- differential signal transmission
- using low noise components
- stable power supplies

## **ACKNOWLEDGMENTS**

Finally, I want to thank H. Walter, who managed the digital handshake to the control system and EPLD programming, as well as H. Reeg, who did all of the mechanical constructions, the boring exploring of core and shielding materials, and the very useful SPICE simulations.